

PATH: u:\P50\Projects\Clients\1521-075-ELST\985Secs\CADD\Phase 19\T03_CV1(Dwg)
 PLOTTED BY: purgaban DATE: Friday, July 07, 2017 4:48:08 PM
 LAYOUT: CSI

CONSTRUCTION NOTES:

- 1 HMA CL. 3/8" PG 64-22.
- 2 5/8" MINUS CRUSHED LEDGE ROCK, 100% FRACTURED. SEE SPECIAL PROVISIONS FOR SPECIFICATIONS.
- 3 RETAINING WALL. SEE AL PLANS FOR LOCATIONS. SEE WP SHEETS FOR WALL PROFILES AND WALL TYPES. SEE SHEET WD1 FOR DETAILS.
- 4 SEE SLOPE RESTORATION DETAILS ON LA SHEETS.
- 5 EXISTING BALLAST BASE.
- 6 SELECT BORROW INCL. HAUL.
- 7 SPLIT RAIL FENCE. COATED CHAIN LINK FENCE TYPE 6 OR GUARDRAIL. SEE AL PLANS FOR LOCATIONS AND TYPES AND SEE DETAILS ON SHEET MD1.
- 8 CRUSHED SURFACING BASE COURSE.
- 9 6" TOPSOIL TYPE A. SEE LA SHEETS FOR PLANTING SCHEDULE.
- 10 STORMWATER DISPERSION AREA. FILL WITH TOPSOIL TYPE A AS NEEDED TO ACHIEVE SLOPE LIMITS. SEE LA SHEETS FOR PLANTING SCHEDULE.

GENERAL NOTES:

1. SEE SHEET CS1 FOR CROSS SLOPE TABLE.

CROSS SLOPE SCHEDULE

ALIGNMENT	STA START	STA END	CROSS SLOPE DIRECTION
B-LINE	283+00	291+00	LT
B-LINE	291+00	317+50	RT
B-LINE	298+75	317+50	LT
B-LINE	317+50	327+00	RT
B-LINE	327+00	338+50	LT
B-LINE	338+50	340+50	RT
B-LINE	340+50	351+50	LT
B-LINE	351+50	359+00	RT
B-LINE	359+00	361+25	LT
B-LINE	361+25	371+06	RT
C-LINE	371+50	379+00	RT
C-LINE	379+00	418+55	LT
D-LINE	419+00	431+63	LT
D-LINE	431+63	459+00	RT
D-LINE	459+00	471+25	LT

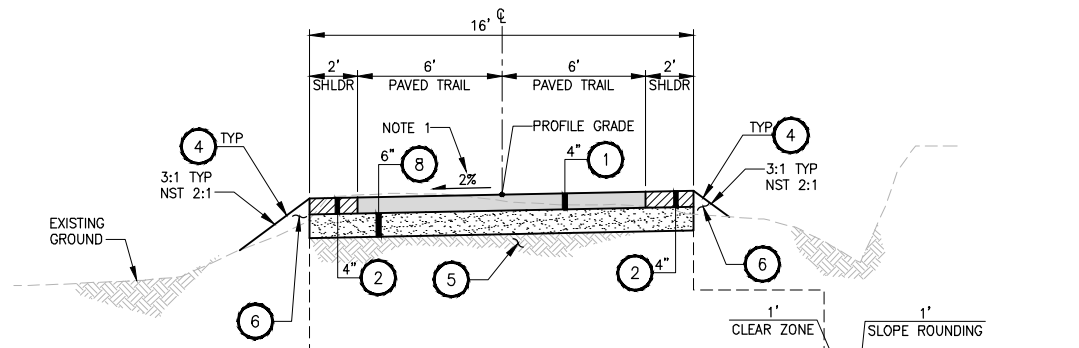

- B-LINE STA 283+23 TO STA 292+25**
B-LINE STA 295+68 TO STA 298+83
B-LINE STA 300+45 TO STA 304+50
B-LINE STA 305+56 TO STA 311+75
B-LINE STA 312+62 TO STA 320+60
B-LINE STA 326+15 TO STA 333+65
B-LINE STA 334+23 TO STA 371+06
C-LINE STA 371+50 TO STA 385+40
C-LINE STA 390+20 TO STA 400+00
C-LINE STA 401+50 TO STA 401+60
C-LINE STA 401+87 TO STA 401+94
C-LINE STA 402+30 TO STA 411+73
C-LINE STA 413+15 TO STA 413+46
D-LINE STA 418+54 TO STA 420+25
D-LINE STA 424+20 TO STA 424+49
D-LINE STA 424+67 TO STA 426+34
D-LINE STA 431+63 TO STA 435+90
D-LINE STA 438+20 TO STA 441+32
D-LINE STA 444+20 TO STA 444+61
D-LINE STA 445+00 TO STA 445+78
D-LINE STA 446+78 TO STA 447+59
D-LINE STA 452+49 TO STA 455+48
D-LINE STA 457+93 TO STA 472+25

SECTION WITHOUT FENCE
TYPICAL SECTION A
 NO SCALE

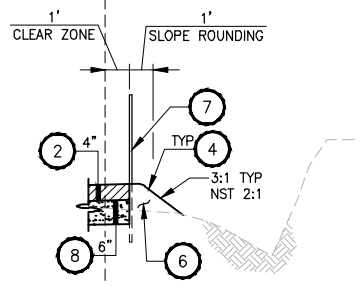

FILL SECTION WITH FENCE

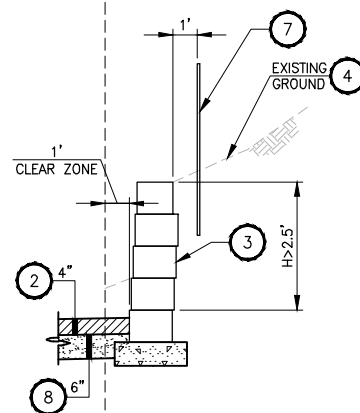

CUT SECTION WITH RETAINING WALL

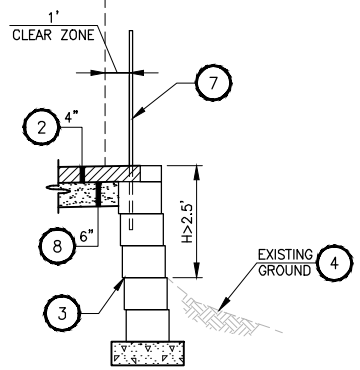

FILL SECTION WITH RETAINING WALL

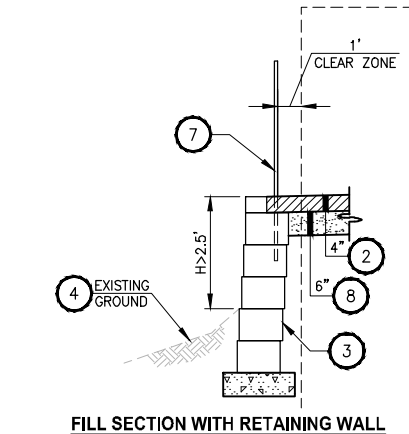

FILL SECTION WITH RETAINING WALL

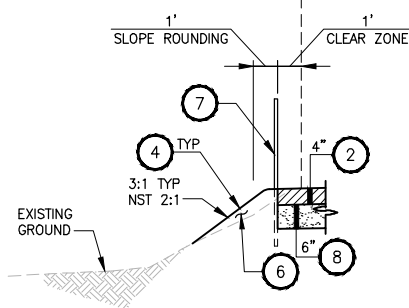

FILL SECTION WITH FENCE

CITY OF SAMMAMISH APPROVAL	
City Engineer _____	Date _____
Community Development _____	Date _____

REVISED 60% REVIEW SUBMITTAL
 NOT FOR CONSTRUCTION

REVISIONS	DATE	BY	DESIGNED
			M. TSUN
			B. PURGANAN
			P. JOHANNESSEN
			Y. HO

ONE INCH AT FULL SCALE, IF NOT, SCALE ACCORDINGLY
 FILE NAME: BL1521075P19T03CS-01
 JOB No.: 554-1521-075 P19 T03
 DATE: JULY 2017

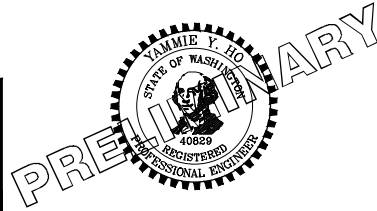

Parametrix
 ENGINEERING · PLANNING · ENVIRONMENTAL SCIENCES
 719 2ND AVENUE, SUITE 200 | SEATTLE, WA 98104
 P 206.394.3700
 WWW.PARAMETRIX.COM

PROJECT NAME
**EAST LAKE SAMMAMISH
 MASTER PLAN TRAIL
 SOUTH SAMMAMISH SEGMENT B**
 SAMMAMISH, WA

TYPICAL CROSS SECTIONS

SHEET NO.
 30 OF 158
CS1

PATH: U:\PSO\Projects\Clients\1521-KingCo\554-1521-075-ELST\99Svcs\CADD\Phase 19\T03_Civil\Draw\ PLOTTED BY: purguban DATE: Friday, July 07, 2017 4:48:14 PM LAYOUT: CS2

CONSTRUCTION NOTES:

- 1 HMA CL. 3/8" PG 64-22.
- 2 5/8" MINUS CRUSHED LEDGE ROCK, 100% FRACTURED. SEE SPECIAL PROVISIONS FOR SPECIFICATIONS.
- 3 RETAINING WALL, SEE AL PLANS FOR LOCATIONS. SEE WP SHEETS FOR WALL PROFILES AND WALL TYPES. SEE SHEET WD1 FOR DETAILS.
- 4 SEE SLOPE RESTORATION DETAILS ON LA SHEETS.
- 5 EXISTING BALLAST BASE.
- 6 SELECT BORROW INCL. HAUL.
- 7 SPLIT RAIL FENCE, COATED CHAIN LINK FENCE TYPE 6 OR GUARDRAIL. SEE AL PLANS FOR LOCATIONS AND TYPES AND SEE DETAILS ON SHEET MD1.
- 8 CRUSHED SURFACING BASE COURSE.
- 9 6" TOPSOIL TYPE A. SEE LA SHEETS FOR PLANTING SCHEDULE.
- 10 STORMWATER DISPERSION AREA. FILL WITH TOPSOIL TYPE A AS NEEDED TO ACHIEVE SLOPE LIMITS. SEE LA SHEETS FOR PLANTING SCHEDULE.

GENERAL NOTES:

1. SEE SHEET CS1 FOR CROSS SLOPE TABLE.

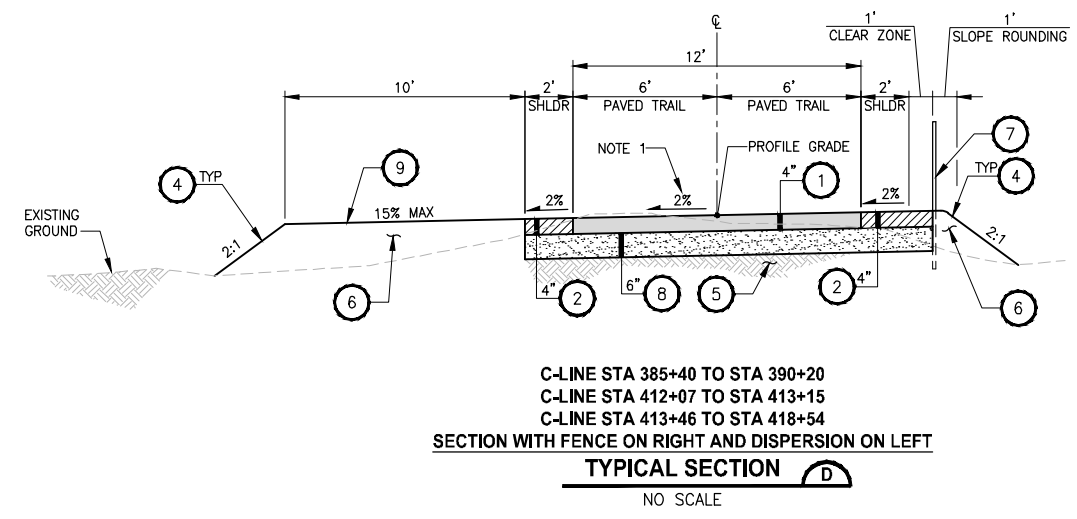
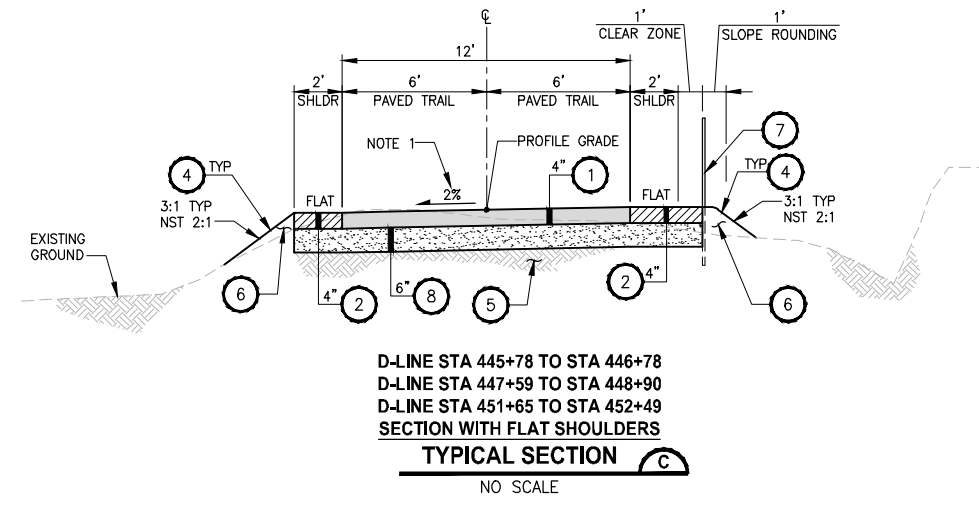
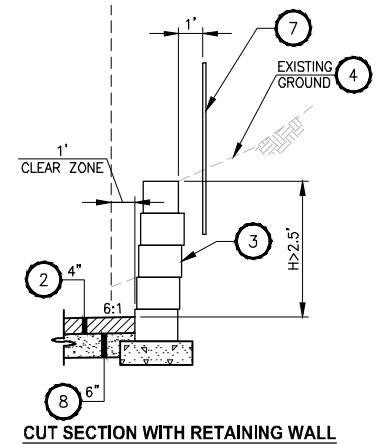
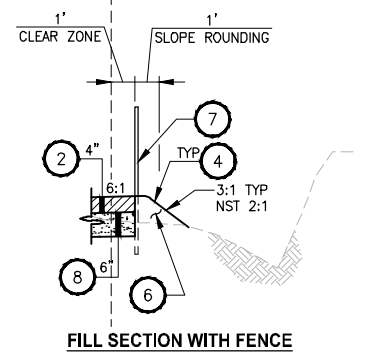
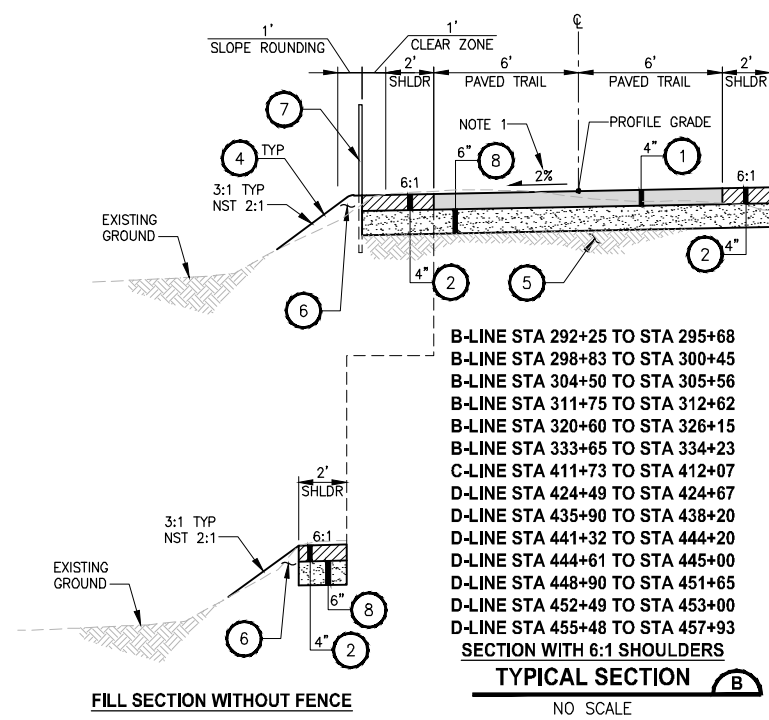

CITY OF SAMMAMISH APPROVAL	
City Engineer _____	Date _____
Community Development _____	Date _____

**REVISED 60% REVIEW SUBMITTAL
NOT FOR CONSTRUCTION**

REVISIONS	DATE	BY	DESIGNED
			M. TSUN
			BPURGANAN
			P. JOHANNESSEN
			Y. HO

ONE INCH AT FULL SCALE.
IF NOT, SCALE ACCORDINGLY

FILE NAME: BL1521075P19T03CS-01
JOB No: 554-1521-075 P19 T03
DATE: JULY 2017

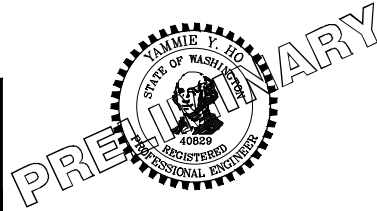

Parametrix
ENGINEERING · PLANNING · ENVIRONMENTAL SCIENCES

719 2ND AVENUE, SUITE 200 | SEATTLE, WA 98104
P 206.394.3700
WWW.PARAMETRIX.COM

PROJECT NAME
**EAST LAKE SAMMAMISH
MASTER PLAN TRAIL
SOUTH SAMMAMISH SEGMENT B**
SAMMAMISH, WA

TYPICAL CROSS SECTIONS

SHEET NO.
31 OF 158

CS2

PATH: U:\PSO\Projects\Clients\1521-KingCo\554-1521-075-ELST\99Svcs\CADD\Phase 19\T03_Civil\Draw\ PLOTTED BY: purgobut DATE: Friday, July 07, 2017 4:48:19 PM LAYOUT: CS3

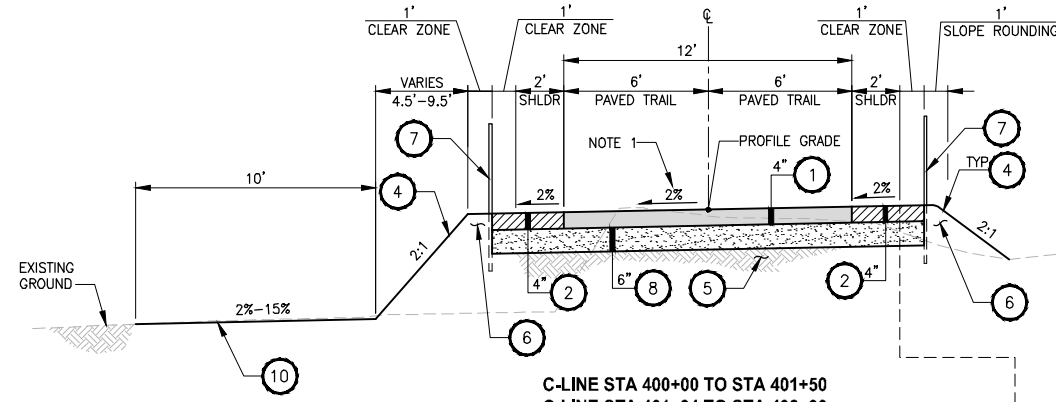

C-LINE STA 400+00 TO STA 401+50
 C-LINE STA 401+94 TO STA 402+30
 C-LINE STA 408+27 TO STA 410+83
 C-LINE STA 411+06 TO STA 411+72
 D-LINE STA 420+25 TO STA 424+20
 D-LINE STA 426+34 TO STA 431+63
SECTION WITH FENCE AND DISPERSION ON LEFT
TYPICAL SECTION E
 NO SCALE

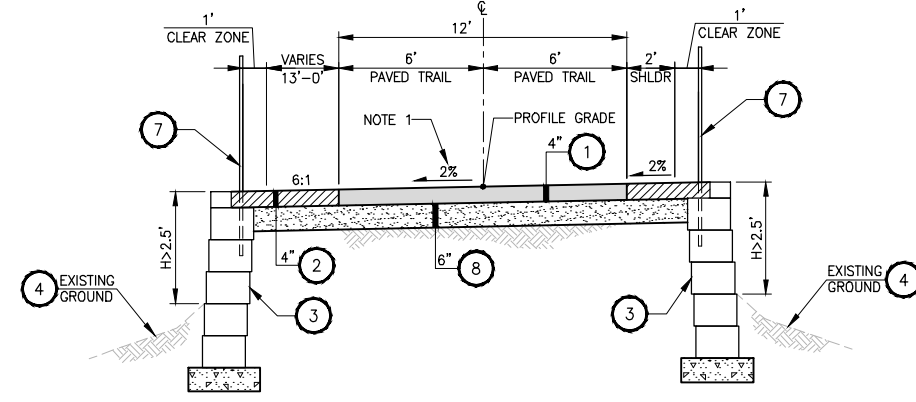

C-LINE STA 401+60 TO STA 401+87
SECTION WITH FILL WALL AND 6:1 SHOULDER (>2' WIDE) ON LEFT
TYPICAL SECTION F
 NO SCALE

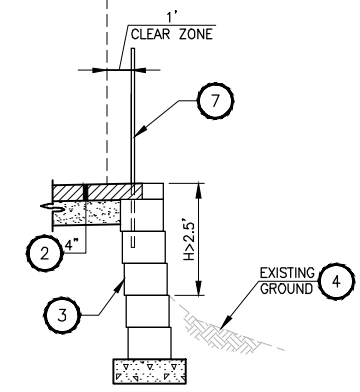

FILL SECTION WITH RETAINING WALL

CONSTRUCTION NOTES:

- 1 HMA CL. 3/8" PG 64-22.
- 2 5/8" MINUS CRUSHED LEDGE ROCK, 100% FRACTURED. SEE SPECIAL PROVISIONS FOR SPECIFICATIONS.
- 3 RETAINING WALL, SEE AL PLANS FOR LOCATIONS. SEE WP SHEETS FOR WALL PROFILES AND WALL TYPES. SEE SHEET WD1 FOR DETAILS.
- 4 SEE SLOPE RESTORATION DETAILS ON LA SHEETS.
- 5 EXISTING BALLAST BASE.
- 6 SELECT BORROW INCL. HAUL.
- 7 SPLIT RAIL FENCE, COATED CHAIN LINK FENCE TYPE 6 OR GUARDRAIL. SEE AL PLANS FOR LOCATIONS AND TYPES AND SEE DETAILS ON SHEET MD1.
- 8 CRUSHED SURFACING BASE COURSE.
- 9 6" TOPSOIL TYPE A. SEE LA SHEETS FOR PLANTING SCHEDULE.
- 10 STORMWATER DISPERSION AREA. FILL WITH TOPSOIL TYPE A AS NEEDED TO ACHIEVE SLOPE LIMITS. SEE LA SHEETS FOR PLANTING SCHEDULE.

GENERAL NOTES:

- 1. SEE SHEET CS1 FOR CROSS SLOPE TABLE.

CITY OF SAMMAMISH APPROVAL	
City Engineer _____	Date _____
Community Development _____	Date _____

REVISED 60% REVIEW SUBMITTAL
 NOT FOR CONSTRUCTION

REVISIONS	DATE	BY	DESIGNED
			M. TSUN
			B. PURGANAN
			P. JOHANNESSEN
			Y. HO

ONE INCH AT FULL SCALE.
 IF NOT, SCALE ACCORDINGLY
 FILE NAME: BL1521075P19T03CS-01
 JOB No.: 554-1521-075 P19 T03
 DATE: JULY 2017

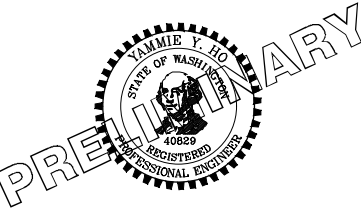

Parametrix
 ENGINEERING · PLANNING · ENVIRONMENTAL SCIENCES
 719 2ND AVENUE, SUITE 200 | SEATTLE, WA 98104
 P 206.394.3700
 WWW.PARAMETRIX.COM

PROJECT NAME
**EAST LAKE SAMMAMISH
 MASTER PLAN TRAIL
 SOUTH SAMMAMISH SEGMENT B**
 SAMMAMISH, WA

TYPICAL CROSS SECTIONS

SHEET NO.
 32 OF 158
CS3